

INTERNATIONAL STANDARD

ISO 9624

First edition
1997-02-15

Thermoplastics pipes for fluids under pressure — Mating dimensions of flange adapters and loose backing flanges

*Tubes en matières thermoplastiques destinés à la pression — Dimensions
des collets et dimensions de raccordement des brides folles plates*

Preview



Reference number
ISO 9624:1997(E)

Foreword

ISO (the International Organization for Standardization) is a worldwide federation of national standards bodies (ISO member bodies). The work of preparing International Standards is normally carried out through ISO technical committees. Each member body interested in a subject for which a technical committee has been established has the right to be represented on that committee. International organizations, governmental and non-governmental, in liaison with ISO, also take part in the work. ISO collaborates closely with the International Electrotechnical Commission (IEC) on all matters of electrotechnical standardization.

Draft International Standards adopted by the technical committees are circulated to the member bodies for voting. Publication as an International Standard requires approval by at least 75% of the member bodies casting a vote.

International Standard ISO 9624 was prepared by Technical Committee ISO/TC 138, *Plastics pipes, fittings and valves for the transport of fluids*, Subcommittee SC 2, *Plastics pipes and fittings for water supplies*.

© ISO 1997

All rights reserved. Unless otherwise specified, no part of this publication may be reproduced or utilized in any form or by any means, electronic or mechanical, including photocopying and microfilm, without permission in writing from the publisher.

International Organization for Standardization
Case postale 56 • CH-1211 Genève 20 • Switzerland
Internet: central@isocs.iso.ch
X.400: c=ch; a=400net; p=iso; o=isocs; s=central

Printed in Switzerland

Thermoplastics pipes for fluids under pressure — Mating dimensions of flange adapters and loose backing flanges

1 Scope

This International Standard specifies the mating dimensions of flange adaptors of thermoplastic materials and the corresponding dimensions of loose backing flanges to be used with thermoplastic pipes under pressure.

It applies to flange adaptors and loose backing flanges for use with pipes with nominal outside diameters d_n from 16 mm to 1 200 mm and nominal pressures up to 16 bar¹⁾ (PN 16).

Tables 2 and 3 specify dimensions for socket fusion systems of polyethylene (PE) and polypropylene (PP) and solvent-cemented systems of unplasticized poly(vinyl chloride) (PVC-U), chlorinated poly(vinyl chloride) (PVC-C) and acrylonitrile/butadiene/styrene (ABS).

Tables 3 to 5 specify dimensions for butt fusion systems of polyethylene (PE) and polypropylene (PP).

2 Normative references

The following standards contain provisions which, through reference in this text, constitute provisions of this International Standard. At the time of publication, the editions indicated were valid. All standards are subject to revision, and parties to agreements based on this International Standard are encouraged to investigate the possibility of applying the most recent editions of the standards indicated below. Members of IEC and ISO maintain registers of currently valid International Standards.

ISO 161-1:1996, *Thermoplastic pipes for the conveyance of fluids — Nominal outside diameters and nominal pressures — Part 1: Metric series.*

ISO 261:1973, *ISO general purpose metric screw threads — General plan.*

ISO 273:1979, *Fasteners — Clearance holes for bolts and screws.*

ISO 727:1985, *Fittings of unplasticized polyvinyl chloride (PVC-U), chlorinated polyvinyl chloride (PVC-C) or acrylonitrile/butadiene/styrene (ABS) with plain sockets for pipes under pressure — Dimensions of sockets — Metric series.*

ISO 7005-1:1992, *Metallic flanges — Part 1: Steel flanges.*

ISO 7279:1984, *Polypropylene (PP) fittings for pipes under pressure — Sockets for fusion using heated tools — Metric series — Dimensions of sockets.*

ISO 8085-1:—²⁾, *Polyethylene fittings for use with polyethylene pipes for the supply of gaseous fuels — Metric series — Specifications — Part 1: Fittings for socket fusion using heated tools.*

1) 1 bar = 10⁵ N/m² = 0,1 MPa

2) To be published.

3 Definitions

For the purposes of this International Standard, the following definitions apply:

3.1 nominal outside diameter, d_n : A numerical designation of size which is common to all components in a thermoplastics piping system other than flanges and components designated by thread size. It is a convenient round number for reference purposes.

3.2 nominal diameter (DN): A numerical designation of size of a flange for reference purposes and only loosely related to manufacturing dimensions.

3.3 nominal pressure (PN):

NOTES

1 The relevant definition of nominal pressure (PN) is given in ISO 161-1 and relates to pipes, fittings (flange adaptors) and components made of thermoplastic materials.

2 The nominal pressure of the flange is used to indicate its geometrical requirements.

The maximum admissible operating pressure of the pipeline to which the flange is connected may vary from the nominal pressure depending upon the operating conditions, particularly in the case of pipelines for gas, chemicals or industrial liquids.

4 Symbols

For the purposes of this International Standard, the following symbols apply:

d_n	nominal (outside) diameter of connecting pipe and nominal (inside) diameter of the socket
D	outside diameter of loose backing flange
DN	size designation of flange
D_1	bolt hole diameter
D_2	inside diameter of loose backing flange
D_3	pitch circle diameter
D_4	outside diameter of flange adaptor head
D_5	outside diameter of flange adaptor shank
n	number of bolt holes

5 Dimensions

5.1 For socket fusion and solvent-cemented systems, the dimensions of the flange adaptor shall conform to those given in table 1. The dimensions of the loose backing flanges shall conform to those given in table 2 for nominal pressure PN 10 (see also figure 1).

NOTE — The thickness of the flange adaptor face will be dependent on the material used in the manufacture of the adaptor and on the nominal pressure for which it is designed.

5.2 For butt fusion systems, the dimensions of the flange adaptors shall conform to those given in table 3. The dimensions at the loose backing flanges shall conform to those given in table 4 for nominal pressure PN 10 and to those given in table 5 for nominal pressure PN 16 (see also figure 2).

NOTE — The thickness of the flange adaptor face will be dependent on the material used in the manufacture of the adaptor and on the nominal pressure for which it is designed.

5.3 The nominal outside diameter d_n of the pipe shall conform to ISO 161-1.

The outside diameter D of the loose backing flange shall conform to ISO 7005-1.

The pitch circle diameter D_3 of the bolts shall conform to ISO 7005-1.

The bolt hole diameter D_1 shall conform to ISO 273.

The inside diameter D_2 of the loose backing flange shall conform to the design of the flange adaptor. In some applications, values of the inside diameter of the loose backing flange differing from those given in the tables may be used.

NOTE — The thickness of the loose backing flanges will be dependent on the material used in the manufacture of the flange and on the nominal pressure (PN) for which it is designed.

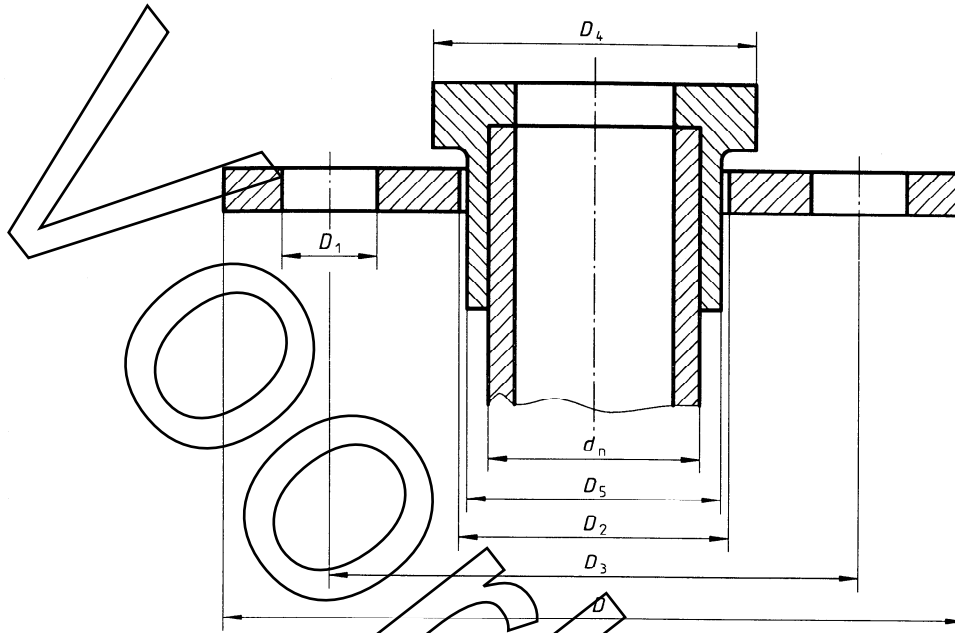

Figure 1 — Socket fusion and solvent-cemented systems

Table 1 — Flange adaptors — Dimensions for socket fusion and solvent-cemented systems

Dimensions in millimetres

Nominal diameter of socket d_n	D_5	D_4 min.
16	$22 \pm 0,1$	29
20	$27 \pm 0,15$	34
25	$33 \pm 0,15$	41
32	$41 \pm 0,2$	50
40	$50 \pm 0,2$	61
50	$61 \pm 0,2$	73
63	$76 \pm 0,3$	90
75	$90 \pm 0,3$	106
90	$108 \pm 0,3$	125
110	$131 \pm 0,3$	150
125	$148 \pm 0,4$	170
140	$165 \pm 0,4$	188
160	$188 \pm 0,4$	213
200	$224 \pm 0,4$	250
225	$248 \pm 0,4$	274
250	$270 \pm 0,5$	306
280	$305 \pm 0,5$	329
315	$342 \pm 0,5$	380

NOTE — Socket dimensions shall conform to the following standards as applicable:

- ISO 727 for PVC-U, PVC-C and ABS
- ISO 7279 for PP
- ISO 8085-1 for PE

Table 2 — Loose backing flange dimensions — Nominal pressure PN 10 for socket fusion and solvent-cemented systems

Dimensions in millimetres

DN	Nominal outside diameter of pipe d_n	Loose backing flanges					
		Outside diameter D	Inside diameter ¹⁾²⁾ D_2	Pitch circle diameter D_3	Bolts		
					Bolt hole diameter D_1	Number n	Screw thread ³⁾
10	16	90	23	60	14	4	M12
15	20	95	28	65	14	4	M12
20	25	105	34	75	14	4	M12
25	32	115	42	85	14	4	M12
32	40	140	51	100	18	4	M16
40	50	150	62	110	18	4	M16
50	63	165	78	125	18	4	M16
65	75	185	92	145	18	4	M16
80	90	200	110	160	18	8	M16
100	110	220	133	180	18	8	M16
125	125	250	150	210	18	8	M16
125	140	250	167	210	18	8	M16
150	160	285	190	240	22	8	M20
200	200	340	226	295	22	8	M20
200	225	340	250	295	22	8	M20
250	280	395	310	350	22	12	M20
300	315	445	348	400	22	12	M20

1) These are standard steel flange dimensions. In some cases, different values may be used for D_2 .

2) Recommended permissible deviation for D_2 :

$\Delta D_2 = -0,5$ when $D_2 \leq 62$ mm

$\Delta D_2 = -1$ when $D_2 > 62$ mm

3) Metric screw thread sizes in millimetres conforming to ISO 261

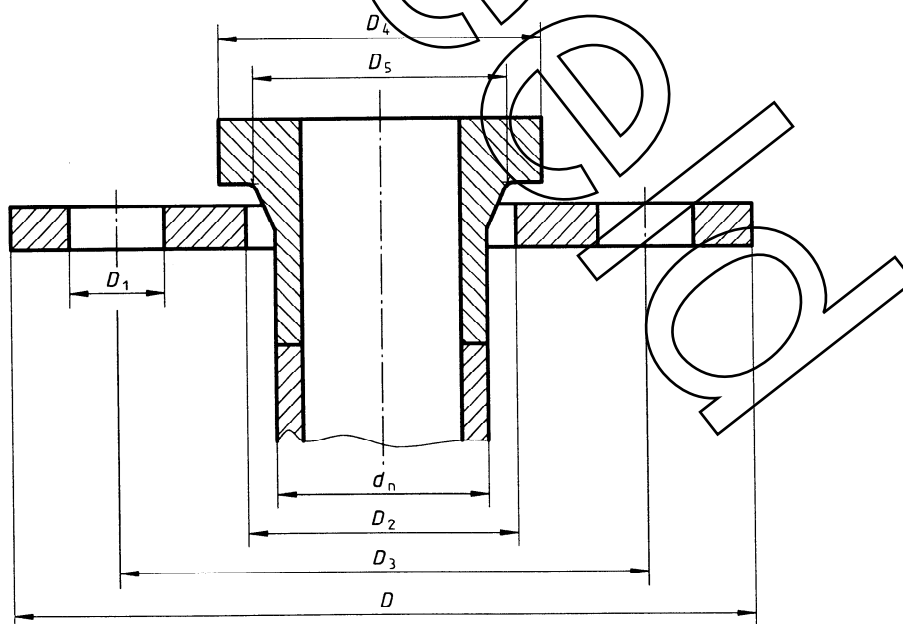

Figure 2 — Butt fusion systems

Bestelformulier

NEN

Stuur naar:

NEN Standards Products & Services
t.a.v. afdeling Klantenservice
Antwoordnummer 10214
2600 WB Delft

NEN Standards Products & Services

Postbus 5059
2600 GB Delft

Vlinderweg 6
2623 AX Delft

T (015) 2 690 390
F (015) 2 690 271

www.nen.nl/normshop

Ja, ik bestel

___ ex. ISO 9624:1997 en Thermoplastics pipes for fluids under pressure - Mating dimensions of flange adapters and loose backing flanges € 48.19

Wilt u deze norm in PDF-formaat? Deze bestelt u eenvoudig via www.nen.nl/normshop

Gratis e-mailnieuwsbrieven

Wilt u op de hoogte blijven van de laatste ontwikkelingen op het gebied van normen, normalisatie en regelgeving? Neem dan een gratis abonnement op een van onze e-mailnieuwsbrieven. www.nen.nl/nieuwsbrieven

Retourneren

Fax: (015) 2 690 271
E-mail: klantenservice@nen.nl
Post: NEN Standards Products & Services,
t.a.v. afdeling Klantenservice
Antwoordnummer 10214,
2600 WB Delft
(geen postzegel nodig).

Gegevens

Bedrijf / Instelling _____

T.a.v. _____ O M O V

E-mail _____

Klantnummer NEN _____

Uw ordernummer _____ BTW nummer _____

Postbus / Adres _____

Postcode _____ Plaats _____

Telefoon _____ Fax _____

Factuuradres (indien dit afwijkt van bovenstaand adres)

Postbus / Adres _____

Postcode _____ Plaats _____

Datum _____ Handtekening _____

Voorwaarden

- De prijzen zijn geldig tot 31 december 2016, tenzij anders aangegeven.
- Alle prijzen zijn excl. btw, verzend- en handelingskosten en onder voorbehoud bij o.m. ISO- en IEC-normen.
- Bestelt u via de normshop een pdf, dan betaalt u geen handeling en verzendkosten.
- Meer informatie: telefoon (015) 2 690 391, dagelijks van 8.30 tot 17.00 uur.
- Wijzigingen en typfouten in teksten en prijsinformatie voorbehouden.
- U kunt onze algemene voorwaarden terugvinden op: www.nen.nl/leveringsvoorwaarden.